



# Setup Sheet



Name \_\_\_\_\_ Date \_\_\_\_\_ Event \_\_\_\_\_ Temp Air \_\_\_\_\_ Track \_\_\_\_\_  
 Track \_\_\_\_\_ Track Condition Indoor Outdoor Tight Open Smooth Rough Wet Dusty Low Bite Med Bite High Bite Other \_\_\_\_\_

## Front

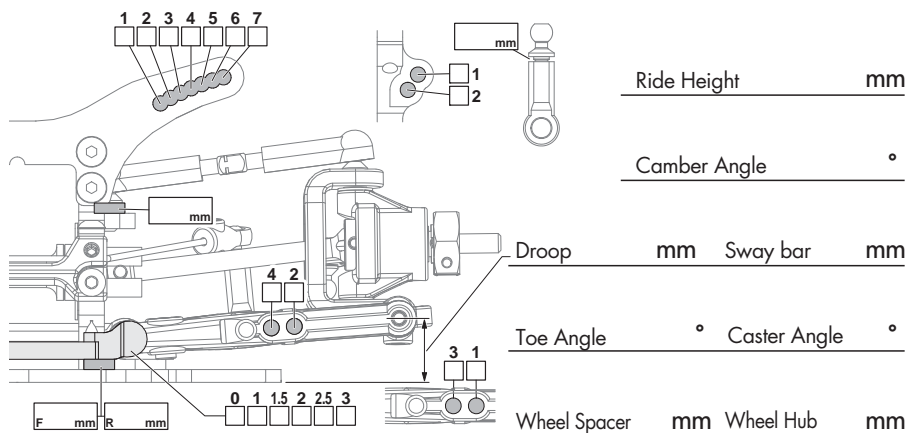

## Shocks

Front \_\_\_\_\_ Rear \_\_\_\_\_

Piston \_\_\_\_\_

Oil wt. \_\_\_\_\_

Bladder \_\_\_\_\_

Spring \_\_\_\_\_

Shock Length \_\_\_\_\_ mm \_\_\_\_\_ mm

## Rear

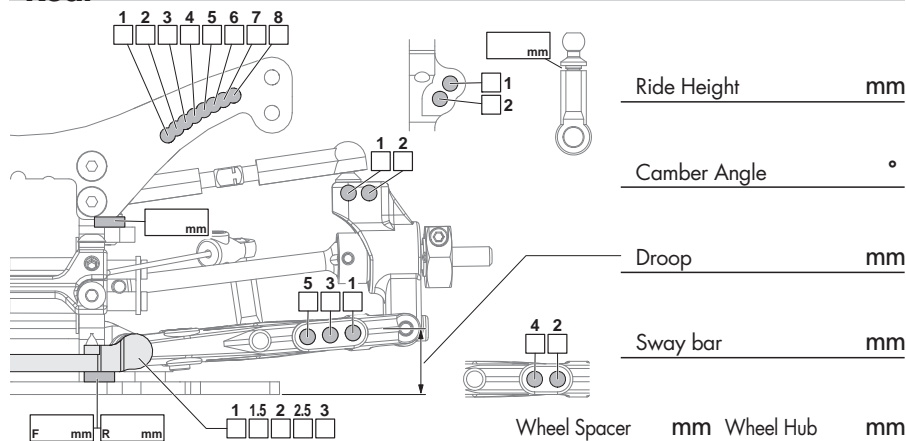

## Tires

Front \_\_\_\_\_ Rear \_\_\_\_\_

Brand \_\_\_\_\_

Compound \_\_\_\_\_

Insert \_\_\_\_\_

Wheel \_\_\_\_\_

Tire Treatment \_\_\_\_\_

## Chassis

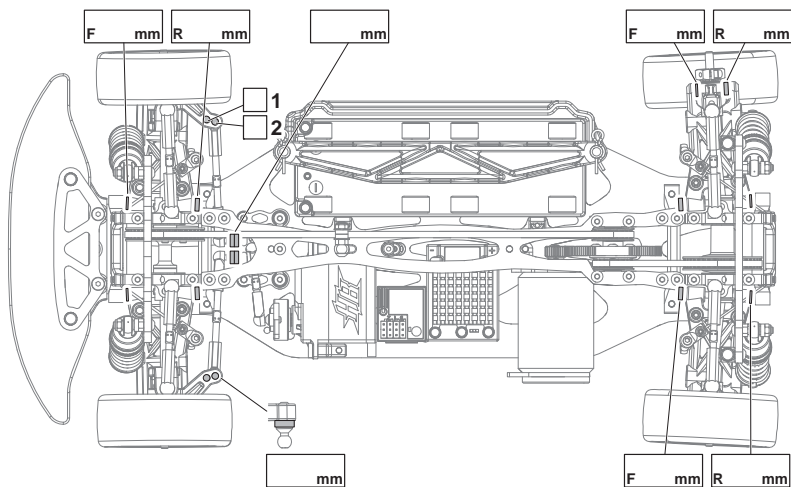

Note \_\_\_\_\_

## Diff

Front \_\_\_\_\_ Rear \_\_\_\_\_

Type \_\_\_\_\_

Note \_\_\_\_\_

## Motor

Motor \_\_\_\_\_ Spur Gear \_\_\_\_\_

Battery \_\_\_\_\_ Pinion Gear \_\_\_\_\_

Body \_\_\_\_\_ ESC \_\_\_\_\_

Wing \_\_\_\_\_ Note \_\_\_\_\_



www.hotbodiesonline.com  
 Hot Bodies USA  
 70 Icon Street  
 Foothill Ranch, CA 92610 USA  
 (949) 753-1099  
 (888) 349-4474 Customer Service

www.hotbodiesonline.com  
 HPI Europe  
 19 William Nadin Way,  
 Swadlincote, Derbyshire,  
 DE11 0BB, UK  
 +44 1283 229400

www.hpiracing.co.jp  
 HPI Japan  
 755-1 Aritama Kita-machi,  
 Higashi-ku, Hamamatsu-shi,  
 Shizuoka 431-3121 JAPAN  
 053-432-6161

www.hpiracing.net.cn  
 HPI China  
 311# Xiangshi Road,  
 Keihan Industrial Park Phase II Standards Plant 6th,  
 Kunshan, JiangSu, China 215312  
 (+86) 512-50320780